



Phone: 877-770-5862

www.PrecisionLiftIndustries.com

## Planning Guide

### The Outdoor Elevator

**This planning guide contains general information on the most popular and standard elevator configurations; and NOT all elevator configurations are shown. This guide has been created to assist in the planning and design of a home elevator for a private residence. This guide is not intended to provide specific information, be used as an owner's manual, or as the only source of preparation for a future elevator installation. Specific questions or concerns should be addressed with a PLI factory sales representative or local authorized dealer.**

#### **Overview:**

Precision Lift Industries, LLC builds high quality residential elevators and vertical platform lifts that are designed with the perfect blend of performance and simplicity. Our residential and outdoor elevators are the perfect solution for new construction and retro fit projects. The winding drum machine provides an energy efficient, smooth, and reliable ride quality without using any hydraulics.

**Space saving design:** The tower on the outdoor elevator is specifically designed to hold all the components of the elevator drive system and take up minimal space while still maintaining a finished look. This includes driving mechanisms as well as the controller box.

**Technologically Advanced:** Our Outdoor Elevator is CNC machine cut to maintain critical tolerances and quality. When combined with a high-quality motor / gearbox with the latest VVVF drive microprocessor controls, it provides years of reliable service.

**Flood zones / Coastal environments:** Our facility is located along the Florida Gulf Coast, and we have seen firsthand the damages that flooding and major storms can cause. The Outdoor Elevator is designed for coastal areas by utilizing high grade aluminum components throughout the elevator design. It is important to understand, that unlike most elevators on the market, these elevators have essentially only the rails at the bottom landing when parked at the top floor.





**PRECISION LIFT**  
INDUSTRIES, LLC

Phone: 877-770-5862

www.PrecisionLiftIndustries.com

## THE OUTDOOR ELEVATOR

SPECIFICATIONS

MODELS	ODE-500 / ODE-750
CAPACITY	500LB / 750LB
SPEED	25 FPM (Nominal)
ODE-500 DRIVE	OVERHEAD WINDING DRUM GEAR MOTOR
ODE-500 SUSPENSION MEANS	2X AIRCRAFT GRADE STAINLESS STEEL CABLES 1/4" IN DIAMETER
ODE-750 DRIVE	COUNTERWEIGHT CHAIN SPROCKET GEAR MOTOR
ODE-750 SUSPENSION MEANS	ANSI #40 ROLLER CHAIN, 1/2 PITCH
SAFETIES	INSTANTANEOUS TYPE "A" SLACK CABLE W/UNDER PAN PRESSURE PLATE
DOOR LOCKS	HONEYWELL RELIALIGN ELECTROMECHANICAL INTERLOCKS
OPERATION	PLC, RELAY, VFD MOTOR CONTROLLER, PLUG'N'PLAY FIELD WIRING
ELECTRICAL REQUIREMENTS	CONTROLLER COMES EQUIPPED WITH A 120VAC PLUG/PIGTAIL. REQUIRES A DEDICATED NON GFCI CIRCUIT, 120VAC, 20AMP OUTLET WITHIN SIGHT OF THE LIFT. FOR JURISDICTIONS WHICH REQUIRE THE CONTROLLER TO BE HARDWIRED, CUT CORD END AND HARD WIRE INTO APPROPRIATE DISCONNECTING MEANS. CORD MAY ALSO BE REMOVED AND REPLACED WITH APPROPRIATE WIRE SUPPLIED BY OTHERS.
CONTROL SYSTEM	PLC, RELAY, VFD MOTOR CONTROLLER, PLUG'N'PLAY FIELD WIRING
CODE	AMSE 18.1.5-2014 PRIVATE RESIDENCE VERTICAL PLATFORM LIFT UNITS OVER 14' OF TRAVEL MAY REQUIRE VARIANCE.

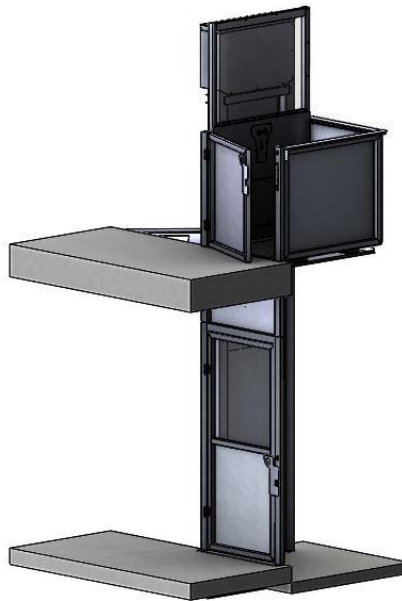



PRECISION LIFT  
INDUSTRIES, LLC

Phone: 877-770-5862

www.PrecisionLiftIndustries.com

### Typical Outdoor Elevator Application:

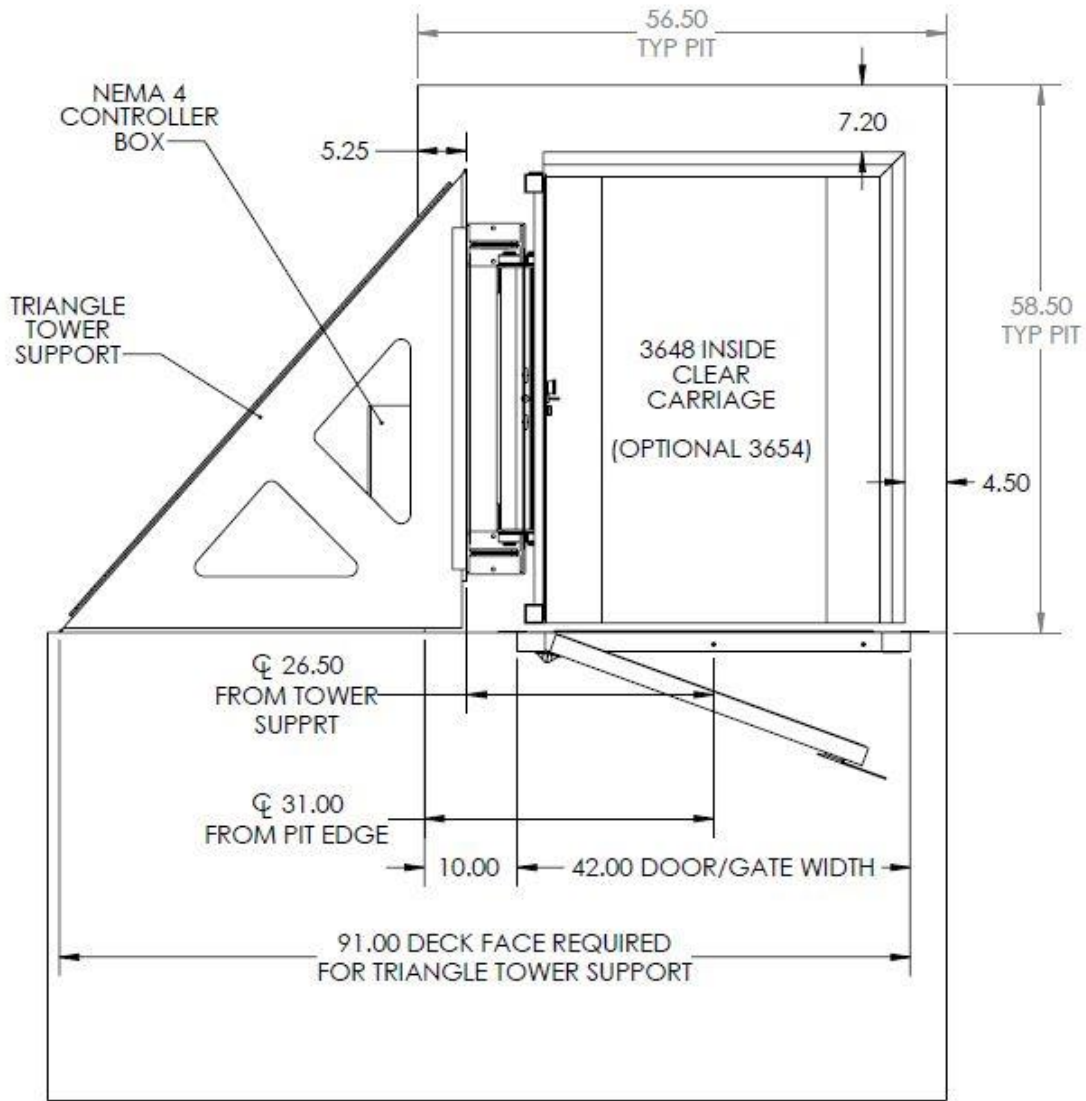



PRECISION LIFT  
INDUSTRIES, LLC

Phone: 877-770-5862

www.PrecisionLiftIndustries.com

### Typical Outdoor Elevator Application:

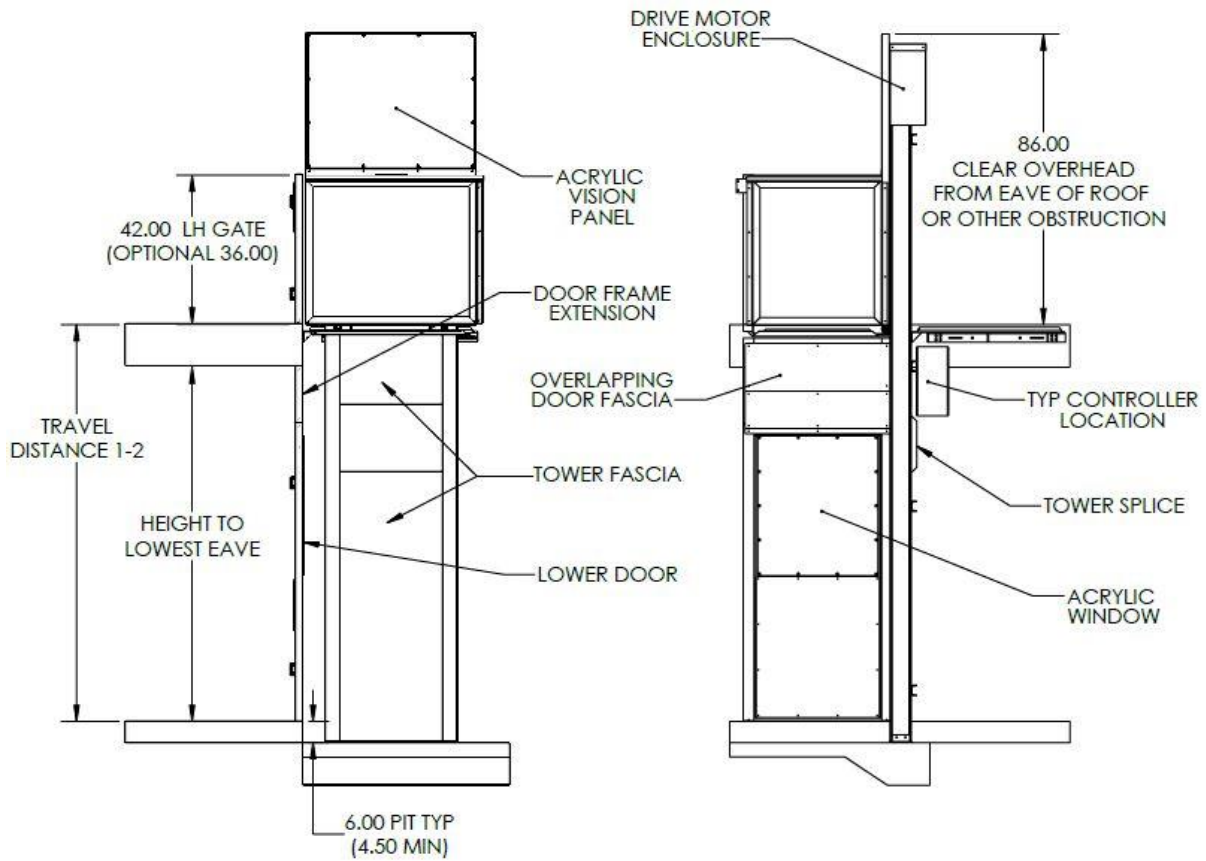



**PRECISION LIFT**  
INDUSTRIES, LLC

Phone: 877-770-5862

www.PrecisionLiftIndustries.com

### Tower Attachment/Support Criteria:

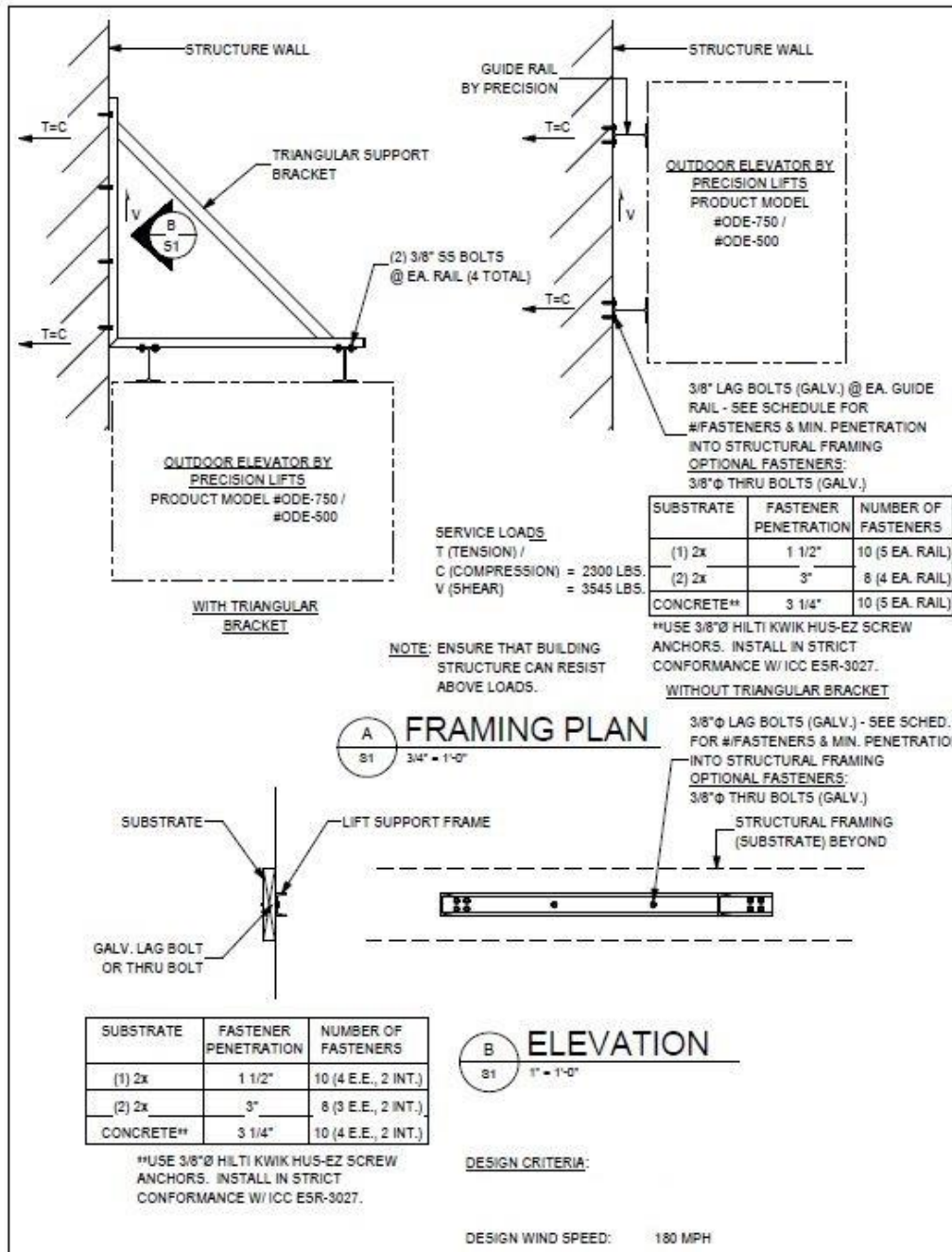





**PRECISION LIFT**  
INDUSTRIES, LLC

Phone: 877-770-5862

www.PrecisionLiftIndustries.com

### Typical Door Configuration:

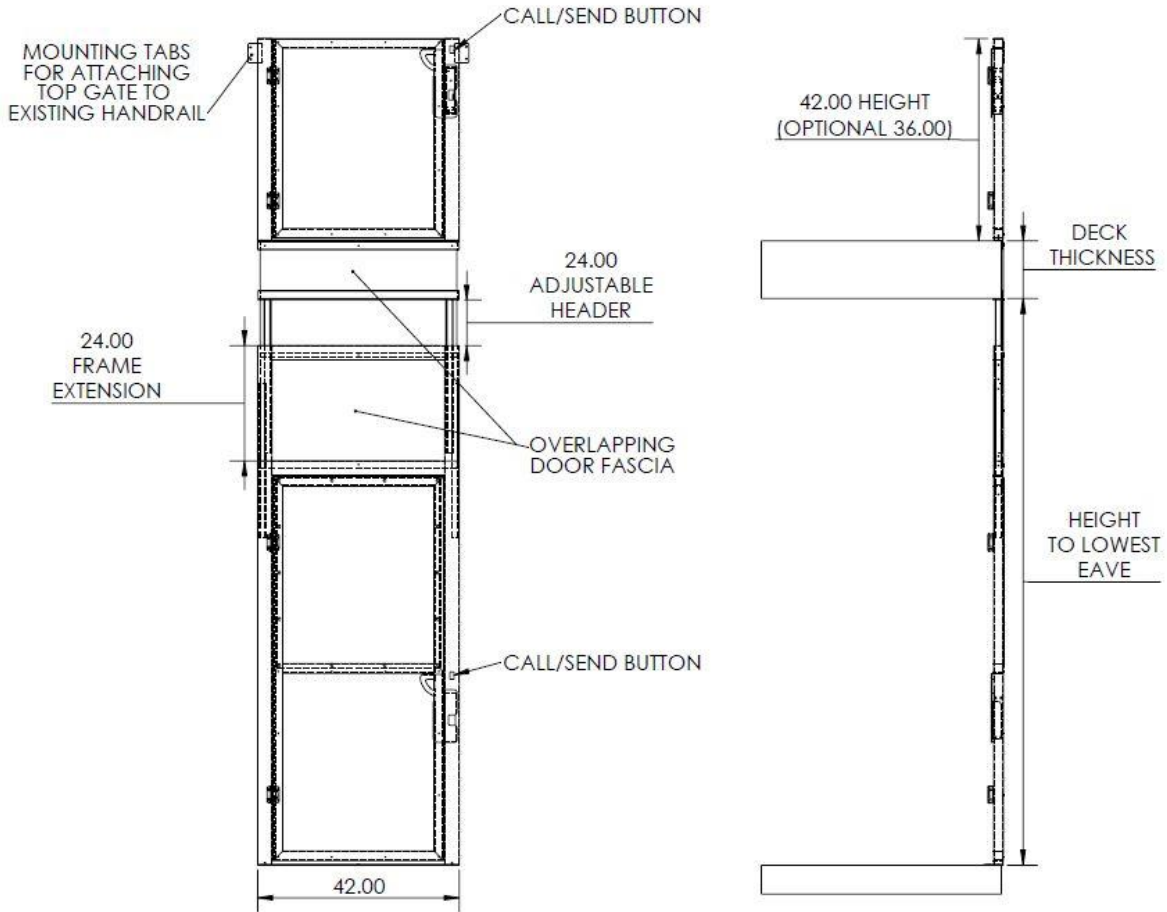

	HEIGHT TO LOWEST EAVE	WIDTH
<b>STANDARD DOOR</b>	84.00-109.00	42.00
24" FRAME EXT	109.00-133.00	42.00
48" FRAME EXT	133.00-157.00	42.00
72" FRAME EXT	157.00-181.00	42.00
<b>STANDARD GATE</b>		
36.00	36.00	42.00
42.00	42.00	42.00





Phone: 877-770-5862

www.PrecisionLiftIndustries.com

### **Pit/Concrete:**

A reinforced concrete pit must be provided at the bottom landing. We recommend a 6" pit depth (4.5" is the minimum). For application without a pit, a 6" Non-ADA ramp can be provided with an I-beam door base. You can also select the I-beam door base separately if ramp will be provided BY OTHERS. When an I-beam door base is used, subtract 6" from the door chart range found on the previous page. The dimensions of the pit must meet the below table based on the size of the carriage desired.

- THIS STRUCTURAL DESIGN IS BASED UPON THE ASSUMPTION THAT THE EXISTING STRUCTURE IS IN GOOD CONDITION AND THAT THAT THE EXISTING STRUCTURE HAS THE CAPACITY TO RESIST PROJECT DESIGN LOADS NOTED ON THESE DRAWINGS. IF THE STRUCTURE HAS OR DEVELOPS WOOD ROT, THE ELEVATOR WILL BECOME UNSAFE
- ATTACHMENT INTO THE EXISTING STRUCTURE SHALL BE PROPERLY WATERPROOFED. WATERPROOFING SYSTEMS ARE BY OTHERS. CHECK WITH YOUR LOCAL JURISDICTION FOR REQUIREMENTS.
- ALL CONCRETE SHALL BE A NORAML WEIGHT AND HAVE A MINIMUM 28-DAY COMPRESSIVE STRENGTH OF 4000PSI.
- FOUNDATIONS HAVE BEEN DESIGNED FOR AN ALLOWABLE SOIL BEARING PRESSURE OF 1500PSF.
- THE SOILS IMMEDIATELY BENEATH ALL FOUNDATIONS SHALL BE COMPACTED FOR A MINIMUM DPETH OF 12 INCHES TO A MINIMUM OF 95% OF THE SOILS MAXIMUM DENSITY AS DETERMINED BY THE MODIFIED PROCTOR TEST ASTM D1557 USING A LARGE TAMPER





**PRECISION LIFT**  
INDUSTRIES, LLC

Phone: 877-770-5862

www.PrecisionLiftIndustries.com

### Pit/Concrete Specifications:

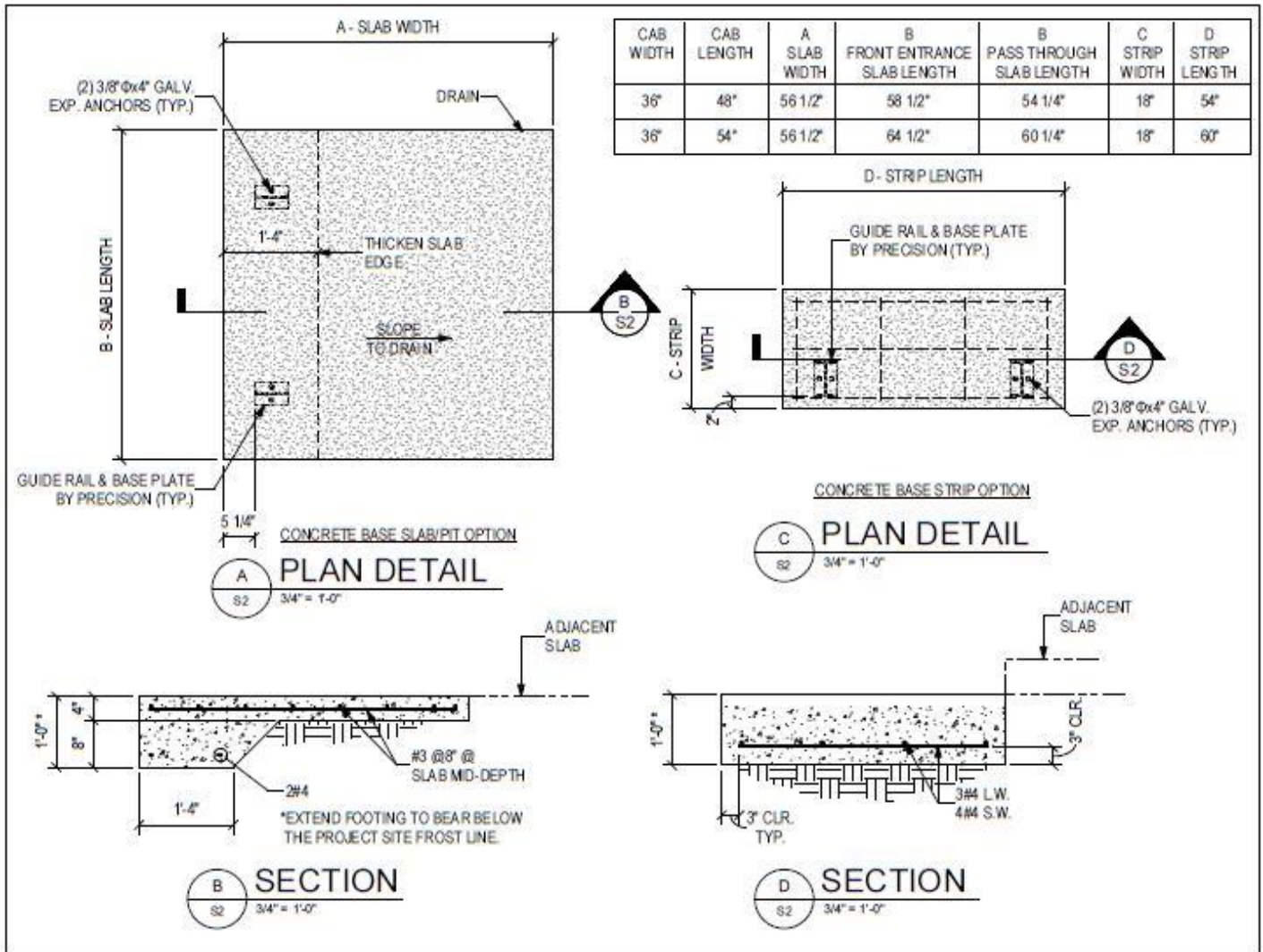





Phone: 877-770-5862

www.PrecisionLiftIndustries.com

### **Electrical Requirements:**

THE CONTROLLER COMES EQUIPPED WITH A 120VAC PLUG/PIGTAIL & REQUIRES A DEDICATED NON GFCI CIRCUIT, 120VAC, 20AMP OUTLET WITHIN SIGHT OF THE LIFT. FOR JURISDICTIONS WHICH REQUIRE THE CONTROLLER TO BE HARDWIRED, CUT CORD END AND HARD WIRE INTO APPROPRIATE DISCONNECTING MEANS. CORD MAY ALSO BE REMOVED AND REPLACED WITH APPROPRIATE WIRE SUPPLIED BY OTHERS.

THE VVFD VARIABLE FREQUENCY DRIVE PROVIDES THE GROUND FAULT CIRCUIT INTERUPTION (GFCI) FOR THE EQUIPMENT AND WILL NOT RUN ON A GFCI PROTECTED SUPPLY CIRCUIT.

### **Work by others:**

- Removal / installation of existing handrail at second floor.
- Removal or modification of existing screens or awnings.
- Provide a 120VAC means of disconnect at desired controller location to the above requirements.
- Provide a concrete pit that meets the minimum requirements.





Phone: 877-770-5862

www.PrecisionLiftIndustries.com

**Recommended ODE-500/750 Maintenance Schedules**

Zone	Coastal Proximity	Minimum Recommended Frequency
Zone 1	Saltwater Beachfront or Saltwater Waterfront	6 visits per year
Zone 2	Non waterfront, within 1 miles of Saltwater	4 visits per year
Zone 3	Non waterfront, 1-7 miles of saltwater	3 visits per year
Zone 4	Freshwater waterfront	2 visits per year
Zone 5	Inland locations 8 miles or greater from saltwater	1 visit per year

**Recommended ODE-500/750 Maintenance Tasks**

Task	Description	Date
Overall Operation	Inspect entire unit. Ride unit to all floor levels, ensure proper operation of door locks, call/send buttons, stop switches. Check for excessive bumps or wear marks. Test safety pan. Cycle safeties. Inspect travel cable and all wiring for signs of damage. Check all bolts for tightness.	
Acrylic glass panels	Inspect all windows, guards, and panels for signs of damage. Inspect fasteners to ensure acrylic glass stays in position.	
Inspect Hinges	Inspect and adjust tension on door hinges as needed.	
Running Clearance	Inspect for signs of house settling. Ensure proper clearances so lift will not bind or physically contact the main building structure.	
Lubricate Door Locks	Remove door locks from door jamb. Pack wire connections with di-electric grease. Seal wires entering door lock with silicone caulk. Spray lower mechanical section of lock with silicone spray.	
Test/Inspect Hall Call Switches	Remove rocker switch from door jamb and apply di-electric grease to wire connections. Replace if signs of extreme corrosion.	
Test/Inspect Limit Switches	Inspect for physical damage. Inspect for excessive corrosion. Replace if "structural rust" is observed.	
Inspect controller plug connections	Inspect for excessive corrosion. Apply di-electric grease as necessary. Zone 1 jobs, painting outside of connectors with clear enamel spray paint is recommended.	
Inspect cable drum or chain sprockets	Inspect for signs of rust. Remove any rust buildup and repaint drum/sprockets with a quality enamel paint (or equal).	
Inspect motor shaft	Inspect for signs of corrosion. Remove any signs of rust or corrosion and apply a film of multipurpose marine grease to any rotation parts.	
Inspect Motor	Inspect motor and brake for signs excessive corrosion. Remove brake cover and inspect brake assembly.	
Inspect flange bearing	Pump zirk fitting with grease. Inspect for signs of corrosion. Remove any signs of rust or corrosion and apply a film of multipurpose marine grease to outside of bearing.	
Inspect Cables/Chains	Inspect for equal tension. Adjust as necessary. Inspect for signs of fraying, knotting or damage of any kind. Replace immediately if damage is observed.	
Lubricate rollers	Apply silicone spray lubricate to the rollers. Run unit up and down and re-apply to ensure lubricant makes its way into the roller hub.	
Inspect Side slide guides	Inspect for signs of wear. Adjust as necessary. Replace as necessary.	
Inspect controller	Check controller for loose wires, signs of water intrusion, signs of tampering. Check battery lowering battery if equipped.	

Cleaning your ODE is an important step to maintain cosmetic finish and mechanical reliability. Your ODE can be washed with any mild soap and water, such as car wash or boat wash. When rinsing your ODE, do not directly spray switches, controller, car operating panel, or door locks. While these components are weather resistant, they are not designed to withstand direct forceful water spray.

Proper maintenance is key to ensuring longevity and reliability on the Outdoor Elevator Product line. Effective on jobs that ship after 11/1/2019, warranty claims will only be approved with proof of proper *documented* maintenance.  
10/2019





Phone: 877-770-5862

www.PrecisionLiftIndustries.com

### The Outdoor Elevator Warranty

Precision Lift Industries, LLC will repair or replace, at our discretion, any part or component, or any defects in materials or workmanship, which fail or occur under normal private residence use during the first 2 years from the date of shipping.

Damages or failures which occur due to misuse, shipping, construction use, vandalism, and acts of god (including but not limited to lightening, flood, fire, wind damages) are not covered by this warranty. Damages or failures which occur during installation and/or result from improper installation are not covered by this warranty. Labor to repair/install replacement parts is not covered by this warranty. Shipping of replacement parts is not included in this warranty. Construction use is defined as use of the elevator by any contractor, subcontractor or individual before final inspection of the elevator or final acceptance from the end user/purchaser. Upon written notice of a warranty claim, Precision Lift Industries, LLC will correct the problematic part/component within a reasonable amount of time. Parts or components in stock shall be shipped within 1 week of the warranty claim. For parts/components which are not in stock or require fabrication, a reasonable lead time will be quoted to the party submitting the warranty claim, and the part/component will be shipped once the part/component is completed.

The Outdoor Elevator comes with a limited lifetime corrosion warranty. Precision Lift Industries will repair or replace (at our discretion) any component (excluding the items listed below) which fails as a direct result of corrosion. Labor to replace or install the components is not included.

Corrosion warranty excludes the drum/sprockets, chain for ODE-750's, drum/sprocket shaft and machine assembly, controller assembly, limit switches. Includes tower and complete carriage assembly. Powder Coating is NOT covered by this warranty. Water Damage to the controller caused by improperly sealed field connections (incoming supply line) is not covered under the warranty.

If you have a warranty claim, promptly submit the claim to [techsupport@pli-team.com](mailto:techsupport@pli-team.com). You must include the job name, serial number and description of the problem. A proper maintenance log filled out in accordance with the Maintenance Recommendation chart on the previous page. Any signed service orders/tickets from the elevator service company detailing the troubleshooting method used to determine the defective part may be required (at our discretion) for certain warranty claims. Upon receipt of the claim, we will contact the party submitting the claim and advise the status of the claim. Precision Lift Industries, LLC reserves the right to request/require more detailed information and/or troubleshooting prior to approving a warranty claim.

